

PowerTech Plus

6068H Diesel Engine

Generator Drive Engine Specifications

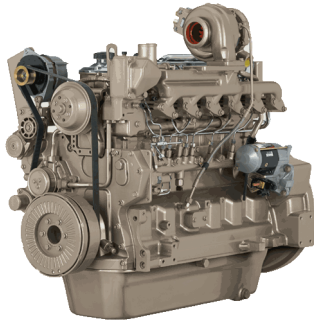

6068H shown

Dimensions

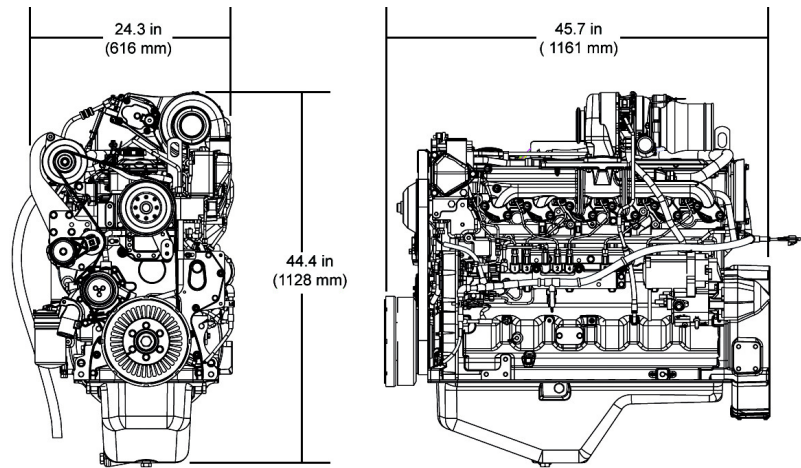

Certifications

CARB
EPA Tier 3

General engine data

Model	6068HF485
Number of cylinders	6
Displacement - L (cu in)	6.8 (415)
Bore and Stroke-- mm (in)	106 x 127 (4.17 x 5.00)
Compression Ratio	17.0:1
Engine Type	In-line, 4-Cycle

Aspiration	Turbocharged and air-to-air aftercooled
Length - mm (in)	1161 (45.7)
Width - mm (in)	616 (24.3)
Height-- mm (in)	1128 (44.4)
Weight, dry-- kg (lb)	678 (1495)

Performance data

Prime power at 60 Hz (1800 rpm)	214 kW (287 hp)
Standby power at 60 Hz (1800 rpm)	235 kW (315 hp)

The prime power gen-set engine rating is the nominal power an engine is capable of delivering with a variable load for an unlimited number of hours per year with normal maintenance intervals observed. This rating incorporates a 10% overload capability which is available for up to 2 hours at a time. Operating time between 100% and 110% of the prime power rating is not to exceed 8% of the total engine operating time. This rating conforms to ISO 8528-1 "prime power (PRP)". The permissible average power for the prime or PRP rating is not to exceed 70% of rated prime power when calculated per ISO 8528-1.

The standby gen-set engine rating is the nominal engine power available at varying load factors for up to 200 hours per year with normal maintenance intervals observed. No overload capability is available for this rating. This rating conforms to ISO 8528-1 "Emergency Standby Power (ESP)". The permissible average power for the standby or ESP rating is calculated per ISO 8528-1.

Performance curve

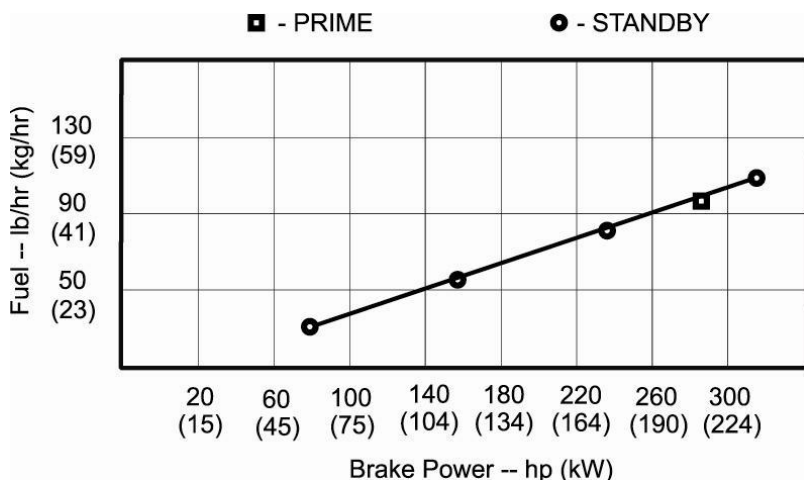

Performance data

Hz (rpm)	Generator efficiency %	Rated fan power		Power factor	Calculated generator set output			
		kW	hp		Prime		Standby	
					kWe	kVa	kWe	kVa
60 (1800)	88-92	14.1	18.9	0.8	176-184	220-230	194-203	243-254

Features and benefits

4-Valve Cylinder Head

- Provides excellent airflow resulting in better transient response
- Cross flow design

High Pressure Common Rail Fuel System

- HPCR: Higher injection pressures, up to 1600 bar (23,000 PSI) variable injection pressure, variable timing control, multiple injections and controls the duration of injection

Cooled Exhaust Gas Recirculation-EGR

- Cools and mixes measured amounts of cooled exhaust gas with incoming fresh air to lower peak combustion temperatures, thereby reducing NOx

Variable Geometry Turbocharger-VGT

- Varies exhaust pressure based on load and speed to insure proper EGR flow, quicker transient response for exceptional block-loading, and best-in-class fuel economy

Air-to-Air Aftercooled

- This is the most efficient method of cooling intake air to help reduce engine emissions while maintaining low-speed torque, transient response time, and peak torque. It enables an engine to meet emissions regulations with better fuel economy and the lowest installed costs

Compact Size

- Horsepower/displacement ratio is best-in-class
- Lower installed cost
- Mounting points for Tier 3/Stage III A engine models same as Tier 2/Stage II engine models

John Deere Electronic Engine Controls

- Monitors critical engine functions providing warning and/or shutdown to prevent costly engine repairs; eliminates need for add-on governing components; all lowering total installed costs. Snapshot diagnostic data that can be retrieved using commonly available diagnostic service tools
- New common wiring interface connector for vehicles or available OEM instrumentation packages; new solid conduit and "T" connectors to reduce wiring stress, greater durability and improved appearance
- Factory installed engine mounted ECU or remote mounted ECU, wiring harness and associated components
- Industry standard SAE J1939 interface which communicates with other vehicle systems, eliminating redundant sensors and reducing vehicle installed cost

Additional Features

- Self adjusting poly-vee fan drive
- R.H. and L.H. engine-mounted fuel filters
- 500-hour oil change

John Deere Power Systems
3801 W. Ridgeway Ave.
PO Box 5100
Waterloo, IA 50704-5100
Phone: 1-800-533-6446
Fax: 319.292.5075

John Deere Power Systems
Usine de Saran
La Foulonnerie - B.P. 11.13
45401 Fleury les Aubrais Cedex
France
Phone: 33.2.38.82.61.19
Fax: 33.2. 38.82.60.00

All values at rated speed and power with standard options unless otherwise noted. Specifications and design subject to change without notice.