

# PowerTech™

## 6090SFM85 Diesel Engine

Marine Propulsion Engine Specifications

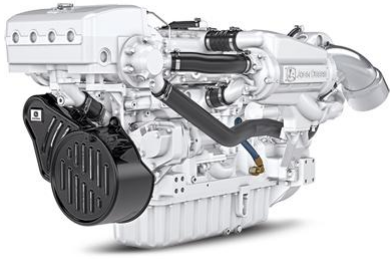

6090SFM85 shown

### Dimensions

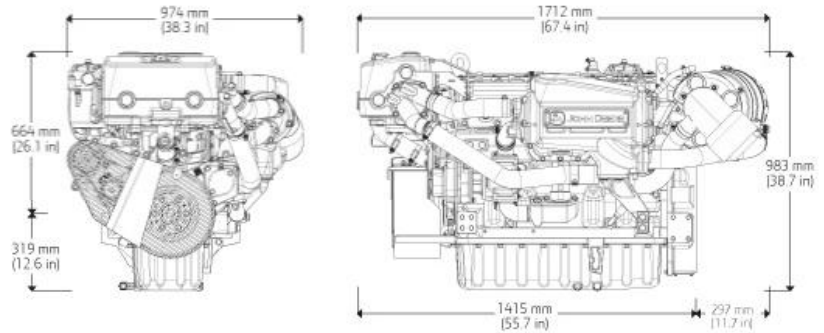

Dimensions shown in mm (in) may vary according to options selected. Contact your distributor for more information.

### Emissions

EPA Commercial Marine Tier 3

IMO MARPOL Annex VI Tier II Compliant

### General Data (Based on Standard Option Configuration)

Model	6090SFM85	Length maximum - mm (in)	1712 (67.4)
Number of cylinders	6	Length to rear face of flywheel housing - mm (in)	1415 (55.7)
Displacement - L (cu in)	9.0 (549)	Flywheel housing SAE	2
Bore and Stroke-- mm (in)	118.4 x 136 (4.66 x 5.35)	Height - mm (in)	983 (38.7)
Engine Type	In-line, 4- Cycle	Height, crankshaft centerline to top - mm (in)	664 (26.1)
Aspiration	Air-to-sea water	Height, crankshaft centerline to bottom - mm (in)	319 (12.6)
		Weight, dry - kg (lb)	1056 (2328)

### Classification Societies

ABS,BV,CCS,DNV-GL,LR

\*SOLAS and other accessories available. Contact your distributor for details.

### Engine Specifications

Performance ratings	Power kW (bhp)	Rated Speed (rpm)	Rated fuel consumption L/hr (gal/hr)
M1	242 (325)	2100	65.4 (17.3)
M2	280 (375)	2200	77.6 (20.5)
M3	317 (425)	2300	87.4 (23.1)
M4	373 (500)	2400	107.1 (28.3)
M5	410 (550)	2500	115.6 (30.5)
H	242 (325)	2000	63.2 (16.7)

Metric hp = Brake hp x 1.01387

H and M rating	M1	M2	M3	M4	M5	H
Typical load factor	> 65%	< =65%	< =50%	< =40%	< =35%	< =70%
Typical annual usage (hr)	Unrestricted	3,000-5,000 hr	2,000-4,000 hr	1,000-3,000 hr	300-1,000 hr	Unrestricted
Typical full-power operation (hr)	Uninterrupted	16 of each 24 hr	4 of each 16 hr	1 of each 12 hr	0.5 of each 8 hr	Uninterrupted

Ratings are based on ISO 8655 standard power rating and the SAE J1 228 crankshaft power rating.

Flexibility of installation due to range of options.

See your John Deere Power Systems engine distributor or marine dealer for more detailed performance information.

## Features and Benefits

### High Torque and Low Rated RPM

- High torque provides excellent vessel control and maneuverability. Lower rated propulsion RPM reduces vibration and noise for improved crew comfort.

### 4-Valve Cylinder Head

- Excellent airflow through 4-valve cylinder head delivers greater low-speed torque and better transient response time.

### High-pressure Common-rail (HPCR)

- The HPCR fuel system provides variable common-rail pressure, multiple injections, and controls fuel injection timing and provides precise control for the start, duration, and end of injection.

### Water-cooled Exhaust Manifold

- Integrated components eliminate external hoses and fittings that can leak or break. Wet exhaust manifold creates a cooler and quieter environment for passengers and crew.

### Turbocharged with Air-to-Seawater Aftercooling

- Cooler turbocharger operation enables higher ratings and efficiencies for applications that require high power or speed.

### Replaceable Cylinder Liners

- Replaceable wet-type cylinder liners are precision-machined and hardened for long life. Allows engine to be rebuilt to original specifications.

### Electronic Engine Control Unit (ECU)

- Advanced fault code diagnostics and customizable engine protections ensure reliability and uptime. Provides highly customizable features and trim to integrate your vessel.

### Heat Exchanger

- High-capacity heat exchanger provides reliable operation in adverse conditions.

### Multiple Service Options

- Either-side oil fill/dipstick combinations and remote oil and fuel filter options are available for easier service access.